



TECHNICAL GUIDE

AFFINITY™ SERIES SPLIT SYSTEM AIR CONDITIONERS

20 SEER – R-410A – 1 PHASE

2 THRU 5 NOMINAL TONS

MODELS: YXV24 THRU 60

FOR INSTALLATION IN ALL US REGIONS AND CANADA



**AMERICAN
QUALITY**
DESIGNED, ENGINEERED &
ASSEMBLED IN THE USA



Due to continuous product improvement, specifications are subject to change without notice.

Visit us on the web at

www.upgnet.com and www.york.com

Additional rating information can be found at

www.ahridirectory.org

WARRANTY SUMMARY*

Extended 10-Years limited parts warranty.

Extended Lifetime limited compressor warranty.

Extended parts and compressor warranties require online registration within 90 days of purchase for replacement or closing for new home construction.

*Does not apply to 3-Phase models, or Internet sales.

See Limited Warranty certificate in User's Information Manual for details.

DESCRIPTION

The Affinity™ Series YXV variable capacity air conditioners are the outdoor section of a high efficiency communicating cooling system. They are designed as part of a matched system using an AVV air handler or variable speed communicating furnace with a CM coil. Both the matched CM coil and AVV air handler have factory mounted EEVs. The CM coils with factory mounted EEVs can also be matched with the variable speed MVC modular air handlers.

FEATURES

- **Superior Coil Protection** – An easily removable two-piece steel extruded louver coil guard protects the tube-in-fin coil from debris and physical damage while making access for coil cleaning quick and simple.
- **Environmentally Friendly Refrigerant** – The next generation refrigerant R-410A delivers environmentally friendly performance with zero ozone depletion.
- **Durable Finish** – A high quality powder paint finish rated at 1000 hrs. salt spray provides the ultimate protection from corrosion and harmful UV rays, ensuring a long-lasting, high quality appearance.
- **Charge Assurance™** – A built-in touch screen instantly displays the system overall condition, including the system pressures and refrigerant charge without the need to attach additional gauges or sensors.
- **QuietDrive™ System** – Features a combination of engineered, sound-neutralizing attributes such as a swept-wing fan blade, composite base pan, multi-density compressor cloak and variable capacity operation to reduce sound levels to that of a mere conversation.
- **ECM Fan Motor** – Dynamically adjusts speed in sync with the compressor demand to keep heat exchange in balance while minimizing power consumption and sound.
- **Swept Wing Fan** – A design adapted from aerospace engineering provides whisper-quiet operation by allowing air to flow smoothly and efficiently across the fan surface and edges.
- **Composite Base Pan** – The strong and durable composite base pan is corrosion resistant while adding strength, absorbing sound, and reducing vibration.
- **High-Efficiency Outdoor Coil** – An aluminum fin and copper tube outdoor coil provide easy cleaning, low restriction to airflow and efficient heat exchange.
- **Factory Installed Filter-Drier** – A corrosion resistant copper solid core liquid line filter-drier removes debris and moisture which can be harmful to the system.
- **Climate Set™** – provides pre-configured operating profiles the installing contractor can select during set-up to fine tune the system's operation for either Humid, Dry, or Normal climates. Additional fine-tune adjustments are always available to provide a custom comfort solution.
- **Easy Service Access** – A large electrical box cover, independent Charge Assurance access, and a swing open electrical box provide superior full corner access to the inside of the unit for maintenance or service.
- **System Protection** – Each system contains high and low pressure transducers which constantly monitor system performance and can alert the consumer or contractor system concerns or alerts.
- **EEV Controls** – All indoor coils, whether in the cased CM coil or in the AVV air handler, have factory installed EEVs (Electronic Expansion Valves).

- **Communications Capable** – Requiring only 3 thermostat wires between the outdoor and indoor units, the communicating system provides self-commissioning on start-up as well as the ability to check system status at the outdoor unit, thermostat, or remotely using the designated App.
- **Variable Capacity Inverter Controlled Scroll Compressor** – Constantly monitors and dynamically adjusts system capacity in precise increments as necessary to closely meet the comfort demands of the conditioned space.
- **Advanced System Control** – The proprietary wi-fi Hx™ thermostat interface is an integral part of this innovative system design. Using the Consumer App, consumers can monitor and adjust their system from anywhere in the world using a smart device. Contractors can use the Service App (with homeowner permission), to monitor the system remotely and make adjustments as needed. The system can be configured to provide alerts for emerging issues as well as items that require immediate attention.
- **Premium System Warranty*** - Limited lifetime compressor warranty when registered online within 90 days of installation.
- **Agency Listed** – Safety certified by CSA to UL 1995 / CSA 22.2. Performance certified to ANSI/AHRI Standard 210/240 in accordance with the Unitary Small Equipment certification program.

LIST OF SECTIONS

DESCRIPTION1
FEATURES1
LIST OF SECTIONS2
NOMENCLATURE2
PHYSICAL AND ELECTRICAL DATA3
DIMENSIONS3
SYSTEM CHARGE FOR VARIOUS MATCHED SYSTEMS4
LIMITATIONS5
SYSTEM CAPACITY - Single Piece and Modular Air Handlers ...5
APPLICATION & ACCESSORIES6
SOUND POWER RATINGS - COOLING6
UNIT OPERATION6
MECHANICAL SPECIFICATIONS7
TYPICAL INSTALLATION8
TYPICAL FIELD WIRING9
ALTERNATIVE INSTALLATION CLEARANCES9
PERFORMANCE DATA - 2 TON10
PERFORMANCE DATA - 3 TON11
PERFORMANCE DATA - 4 TON12
PERFORMANCE DATA - 5 TON13

NOMENCLATURE

BRAND	Y	Y = York
PRODUCT TYPE	X	X = Premium Air Conditioner
NOMINAL SERIES EFFICIENCY AND STAGING	V	V = 20 SEER / Modulating
NOMINAL UNIT CAPACITY (MBH)	36	24 = 2 Ton 48 = 4 Ton 36 = 3 Ton 60 = 5 Ton
REFRIGERANT	B	B = R-410A
VOLTAGE (Voltage-Phase-Hertz)	2	2 = 208/230-1-60
GENERATION (MAJOR REVISION)	1	1 = 1st Gen 2 = 2nd Gen etc
FACTORY OPTION	S	S = Standard (No Options) H = Hard Start Kit
STYLE LETTER (MINOR REVISION) NOT USED FOR ORDERING	A	A = Style A B = Style B etc.

PHYSICAL AND ELECTRICAL DATA

MODEL		YXV24B21S	YXV36B21S	YXV48B21S	YXV60B21S
Unit Supply Voltage		208-230V, 1 ϕ , 60Hz			
Normal Voltage Range ¹		187 to 252			
Minimum Circuit Ampacity		17.4	25.7	28.6	33.9
Max. Overcurrent Device Amps ²		30	40	45	50
Compressor	Type	Scroll	Scroll	Scroll	Scroll
	Rated Load	12.8	19.2	20.8	25.0
	Locked Rotor	23.0	35.0	35.0	50.0
Crankcase Heater (Stator Heat)		Yes	Yes	Yes	Yes
HS Kit Required with TXV		N/A	N/A	N/A	N/A
Fan Diameter Inches		24	24	26	26
Fan Motor	Rated HP	1/8	1/4	1/3	1/3
	Rated Load Amps	1.4	1.7	2.6	2.6
	Nominal RPM	1025	1025	975	1050
	Nominal CFM	3500	3900	4800	5300
Coil	Face Area Sq. Ft.	23.82	23.82	28.80	31.2
	Rows Deep	1	1	2	2
	Fins / Inch	22	22	18	18
Liquid Line Set OD (Field Installed)		3/8	3/8	3/8	3/8
Vapor Line Set OD (Field Installed) ³		3/4	3/4	7/8	7/8
Unit Charge (Lbs. - Oz.) ⁴		7 - 8	7 - 6	14 - 9	15 - 1
Charge Per Foot, Oz.		0.62	0.62	0.67	0.67
Operating Weight Lbs.		194	205	264	270

1. Rated in accordance with AHRI Standard 110-2012, utilization range "A".
2. Dual element fuses or HACR circuit breaker. Maximum allowable overcurrent protection.
3. For applications with non-standard vapor line sizes, see the "Applications & Accessories" section of this Technical Guide.
4. The Unit Charge is correct for the outdoor unit, smallest matched indoor unit, and 15 feet of refrigerant tubing. For tubing lengths other than 15 feet, add or subtract the amount of refrigerant, using the difference in actual lineset length (not the equivalent length) multiplied by the per foot value.

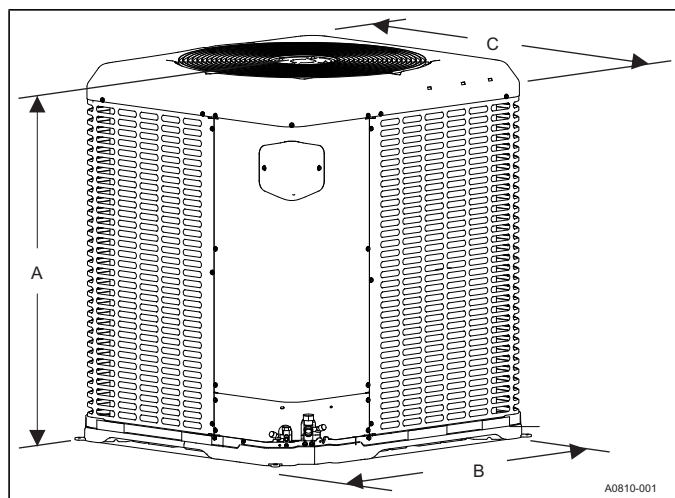
**DIMENSIONS**

Unit Model	Dimensions (Inches)			Refrigerant Connection Service Valve Size	
	A	B	C	Liquid	Vapor
YXV24B21S	40-1/4	35-1/2	32	3/8	3/4
YXV36B21S	40-1/4	35-1/2	32		
YXV48B21S	43-1/4	38-1/4	34-1/2		7/8
YXV60B21S	46-1/2	38-1/4	34-1/2		

All dimensions are in inches and are subject to change without notice.
 Overall height is from bottom of base pan to top of fan guard.
 Overall length and width include screw heads.

SYSTEM CHARGE FOR VARIOUS MATCHED SYSTEMS

Outdoor Unit	YXV24B21S	YXV36B21S	YXV48B21S	YXV60B21S
Indoor Unit ¹	Additional Charge, oz			
AVV25BE121	0	-	-	-
AVV37BE221	-	0	-	-
AVV37CE221	-	0	-	-
AVV49CE321	-	-	0	-
AVV49DE321	-	-	0	-
AVV61CE421	-	-	-	0
AVV61DE421	-	-	-	0
CM25BE1A1	0	-	-	-
CM37BE2A1	-	0	-	-
CM37CE2A1	-	0	-	-
CM49CE3A1	-	-	0	-
CM49DE3A1	-	-	0	-
CM61CE4A1	-	-	-	0
CM61DE4A1	-	-	-	0
All of the combinations shown in the above System Charge table require Advanced Main Air Circulating Fan indoor product. "Coil Only" matches are not available for these systems.				

FOOTNOTES:

- Charge adders shown above do not indicate that coils are rated for every application. Refer to Performance Data Tables for actual performance for specified system matches. Obtain certified system ratings from www.ahridirectory.org.

CHARGING PROCEDURES:

- Determine outdoor unit factory charge from Tabular Data Sheet.
- Determine indoor coil adjustment (if any) from Tabular Data Sheet.
- Calculate the additional charge for refrigerant piping using this Tabular Data Sheet if line length is greater than 15 feet (4.6 m).
- Total system charge = item 1 + item 2 + item 3.
- The manifold gauge set is already installed on the unit for evacuation and charging. Use these gauges to initially charge the system using system pressures and subcooling. Before charging put the equipment into "Service Mode" at the outdoor control. You will find the charging information printed on the bottom of the unit data tag. More charging information is available in the "Service Data Application Guide", available online. For subsequent annual maintenance visits the charge verification display can be used to quickly check overall system condition and the system charge without attaching a separate manifold gauge set or temperature sensors.
- Permanently mark the unit data plate with the total amount of refrigerant in the system.

IMPORTANT

It is recommended before starting the system to connect the thermostat to Wi-Fi using a local network or portable hot-spot so the thermostat and system receive the latest software updates to optimize system performance.

LIMITATIONS

The unit should be installed in accordance with all National, State and Local Safety Codes and the limitations listed below:

1. Limitations for the indoor unit, coil, and appropriate accessories must also be observed.
2. The outdoor unit must not be installed with any duct work in the air stream. The outdoor fan is the propeller type and is not designed to operate against any additional external static pressure.
3. The maximum and minimum conditions for operation must be observed to ensure a system will give maximum performance with minimal service.

Minimum / Maximum Operating Limit Conditions

AIR TEMPERATURE AT OUTDOOR COIL, ° F (° C)		AIR TEMPERATURE AT INDOOR COIL, ° F (° C)	
Min.	Max.	Min.	Max.
DB Cool	DB Cool	WB Cool	WB Cool
35(2)*	125(52)*	57(14)	72(22)

*Reference the NOTICE under the "Unit Reduced Capacity Conditions" section.

4. The maximum allowable equivalent line length for this product is 80 feet.

Standard Lineset Applications

Maximum allowable lineset varies depending on the vertical separation between the evaporator and condenser. See Table 2 for allowable line set lengths and sizing.

Allowable Vertical Linesets

Model	Liquid Line	Suction Line	Max Line Length - Units on Equal Level	Max Suction Line Riser - If OD Unit is Above ID Unit	Max Liquid Line Riser - If OD Unit is Below ID Unit
24	3/8"	3/4"	80 feet	25 feet	25 feet
36					
48		7/8"			
60					

Unit Reduced Capacity Conditions

NOTICE

Inverter Temperature Protection:

If excessive inverter temperatures are sensed, the compressor speed / capacity is reduced until an acceptable condition is reached.

When the inverter temperature returns to an acceptable level, the system returns to normal operation.

Over / Under Current Protection: *If a low or high Current Condition is sensed, the compressor speed / capacity is reduced until an acceptable current level is reached.*

When the system reaches an acceptable current level, the compressor and fan return to normal operating conditions.

Over / Under Voltage Protection: *If a low or high supply Voltage Condition is experienced (below 187 VAC or above 265 VAC), the compressor speed / capacity is automatically reduced until an acceptable voltage level is sensed.*

When an acceptable voltage level is sensed, the system automatically returns to a normal state of operation.

High Altitude Protection: *If the unit is installed in Altitudes of 6,500 ft / 2,000 m above sea level or higher, the compressor and outdoor fan reduce speeds to protect the system. It is not recommended these units be installed at altitudes greater than 6,500 ft / 2,000 m above sea level.*

Low Ambient Protection:

Cooling Mode: *The unit automatically adjusts to maintain cooling operation in outdoor ambient conditions down to 35° F (2° C). The unit reduces capacity and Low Ambient Protection (cooling mode) or cycles off if asked to provide cooling when the outdoor temperature is at or below these conditions.*

SYSTEM CAPACITY - Single Piece and Modular Air Handlers

UNIT MODEL	AIR HANDLER		COIL MODEL ³	Stage	RATED CFM	COOLING			
	MODEL	WIDTH				NET MBH		SEER	EER
						TOTAL	SENS.		
YXV24B21S	AVV25BE12	17.5	-	High	775	23.4	17.7	19.25	14.00
				Med	500	14.1	11.2	-	18.50
				Low	350	10.0	7.9	-	34.30
YXV24B21S	MVC12BN21	17.5	CM25BE1A1	High	850	23.4	18.3	19.00	14.00
				Med	425	14.0	10.5	-	18.10
				Low	375	10.0	8.3	-	34.25
YXV36B21S	AVV37BE22	17.5	-	High	1250	34.8	26.6	17.25	12.75
				Med	700	18.8	15.3	-	17.00
				Low	450	11.2	9.7	-	31.00
YXV36B21S	MVC12BN21	17.5	CM37BE2A1	High	1175	34.4	25.6	17.25	12.50
				Med	700	18.9	15.4	-	16.90
				Low	450	11.2	9.7	-	31.00
YXV36B21S	AVV37CE22	21.0	-	High	1200	35.0	25.8	19.00	13.25
				Med	700	19.0	14.6	-	18.00
				Low	400	11.2	8.9	-	33.00
YXV36B21S	MVC16CN21	21.0	CM37CE2A1	High	1175	34.8	26.0	17.75	12.75
				Med	675	18.9	15.3	-	17.25
				Low	475	11.3	10.0	-	31.90
YXV48B21S	AVV49CE32	21.0	-	High	1450	45.0	32.4	19.25	13.00
				Med	825	25.2	19.8	-	18.95
				Low	475	14.2	11.3	-	34.70
YXV48B21S	MVC16CN21	21.0	CM49CE3A1	High	1450	45.0	32.4	19.25	12.75
				Med	825	25.2	19.8	-	18.95
				Low	475	14.2	11.3	-	34.70
YXV48B21S	AVV49DE32	24.5	-	High	1500	45.5	34.2	19.50	13.00
				Med	800	25.2	18.5	-	19.10
				Low	500	14.9	11.5	-	36.20
YXV48B21S	MVC20DN21	24.5	CM49DE3A1	High	1475	45.0	32.4	19.50	12.75
				Med	850	25.4	20.0	-	19.10
				Low	450	14.1	11.1	-	34.65
YXV60B21S	AVV61CE42	21.0	-	High	1600	52.5	37.2	19.50	12.75
				Med	950	29.6	23.0	-	18.80
				Low	700	20.6	16.4	-	36.20
YXV60B21S	AVV61DE42	24.5	-	High	1600	52.5	38.5	20.00	13.00
				Med	1000	30.4	23.4	-	19.10
				Low	700	20.8	16.6	-	36.25
YXV60B21S	MVC20DN21	24.5	CM61DE4A1	High	1825	52.5	39.0	20.00	13.00
				Med	975	30.2	23.4	-	19.10
				Low	725	20.6	16.7	-	36.00

Rated in accordance with DOE test procedures (Federal Register 12-27-79 and 3-18-88) and ANSI/AHRI Standard 210/240.

Cooling MBH based on 80°F entering air temperature, 50% RH (Relative Humidity), and rated air flow.

EER (Energy Efficiency Ratio) is the total cooling output in BTUs at 95°F outdoor ambient divided by the total electric power in watt-hours at those conditions.

SEER (Seasonal Energy Efficiency Ratio) is the total cooling output in BTUs during a normal annual usage period for cooling divided by the total electric power input in watt-hours during the same period.

— = Not applicable.

CM coils available with a factory installed horizontal drain pan. See price pages for specific model number.

COOLING CAPACITY - With High Efficiency Motor Furnaces¹

UNIT MODEL	FURNACE		COIL MODEL ²	STAGE	COOLING				
	MODEL	WIDTH			RATED CFM	NET MBH		SEER	EER
						TOTAL	SENS.		
YXV24B21S	TM9V060B12MP11	17.5	CM25BE1A1	High	725	23.0	17.0	19.00	13.75
				Med	400	13.9	10.3	–	18.00
				Low	275	9.5	7.1	–	33.10
YXV24B21S	TM9V080B12MP11	17.5	CM25BE1A1	High	725	23.0	17.0	19.00	13.75
				Med	400	13.9	10.3	–	18.00
				Low	275	9.5	7.1	–	33.10
YXV24B21S	TP9C060B12MP12	17.5	CM25BE1A1	High	725	23.0	17.0	19.00	13.75
				Med	400	13.9	10.3	–	18.00
				Low	275	9.5	7.1	–	33.10
YXV24B21S	TP9C080B12MP12	17.5	CM25BE1A1	High	725	23.0	17.0	19.00	13.75
				Med	400	13.9	10.3	–	18.00
				Low	275	9.5	7.1	–	33.10
YXV24B21S	YP9C060B12MP12	17.5	CM25BE1A1	High	725	23.0	17.0	19.00	13.75
				Med	400	13.9	10.3	–	18.00
				Low	275	9.5	7.1	–	33.10
YXV24B21S	YP9C080B12MP12	17.5	CM25BE1A1	High	725	23.0	17.0	19.00	13.75
				Med	400	13.9	10.3	–	18.00
				Low	275	9.5	7.1	–	33.10
YXV36B21S	TM9V060B12MP11	17.5	CM37BE2A1	High	1225	34.4	26.2	17.00	12.20
				Med	550	18.2	13.5	–	16.75
				Low	300	10.5	7.6	–	30.15
YXV36B21S	TM9V080B12MP11	17.5	CM37BE2A1	High	1225	34.4	26.2	17.00	12.20
				Med	550	18.2	13.5	–	16.75
				Low	300	10.5	7.6	–	30.15
YXV36B21S	YP9C060B12MP12	17.5	CM37BE2A1	High	1225	34.4	26.2	17.00	12.20
				Med	550	18.2	13.5	–	16.75
				Low	300	10.5	7.6	–	30.15
YXV36B21S	YP9C080B12MP12	17.5	CM37BE2A1	High	1225	34.4	26.2	17.00	12.20
				Med	550	18.2	13.5	–	16.75
				Low	300	10.5	7.6	–	30.15
YXV36B21S	TM8V080C16MP11	21.0	CM37CE2A1	High	1200	34.8	26.2	17.25	12.75
				Med	600	18.5	14.2	–	17.00
				Low	475	11.3	10.0	–	31.25
YXV36B21S	TM8V100C16MP11	21.0	CM37CE2A1	High	1200	34.8	26.2	17.25	12.75
				Med	600	18.5	14.2	–	17.00
				Low	475	11.3	10.0	–	31.25
YXV36B21S	TM9V080C16MP11	21.0	CM37CE2A1	High	1150	34.8	25.8	17.25	13.00
				Med	600	18.5	14.2	–	17.00
				Low	400	11.0	9.0	–	30.55
YXV36B21S	TM9V100C16MP11	21.0	CM37CE2A1	High	1150	34.8	25.8	17.25	13.00
				Med	600	18.5	14.2	–	17.00
				Low	400	11.0	9.0	–	30.55
YXV36B21S	TMLV080C16MP11	21.0	CM37CE2A1	High	1200	34.8	26.2	17.25	12.75
				Med	600	18.5	14.2	–	17.00
				Low	475	11.3	10.0	–	31.25
YXV36B21S	TMLV100C16MP11	21.0	CM37CE2A1	High	1200	34.8	26.2	17.25	12.75
				Med	600	18.5	14.2	–	17.00
				Low	475	11.3	10.0	–	31.25
YXV36B21S	TP9C080C16MP12	21.0	CM37CE2A1	High	1150	34.8	25.8	17.25	13.00
				Med	600	18.5	14.2	–	17.00
				Low	400	11.0	9.0	–	30.55

Continued on next page.

COOLING CAPACITY - With High Efficiency Motor Furnaces¹ (Continued)

UNIT MODEL	FURNACE		COIL MODEL ²	STAGE	COOLING				
	MODEL	WIDTH			RATED CFM	NET MBH		SEER	EER
						TOTAL	SENS.		
YXV36B21S	TP9C100C16MP12	21.0	CM37CE2A1	High	1150	34.8	25.8	17.25	13.00
				Med	600	18.5	14.2	–	17.00
				Low	400	11.0	9.0	–	30.55
YXV36B21S	TPLC080C16MP12	21.0	CM37CE2A1	High	1200	34.8	26.2	17.25	12.75
				Med	600	18.5	14.2	–	17.00
				Low	475	11.3	10.0	–	31.25
YXV36B21S	TPLC100C16MP12	21.0	CM37CE2A1	High	1200	34.8	26.2	17.25	12.75
				Med	600	18.5	14.2	–	17.00
				Low	475	11.3	10.0	–	31.25
YXV36B21S	YP9C080C16MP12	21.0	CM37CE2A1	High	1150	34.8	25.8	17.25	13.00
				Med	600	18.5	14.2	–	17.00
				Low	400	11.0	9.0	–	30.55
YXV36B21S	YP9C100C16MP12	21.0	CM37CE2A1	High	1150	34.8	25.8	17.25	13.00
				Med	600	18.5	14.2	–	17.00
				Low	400	11.0	9.0	–	30.55
YXV36B21S	YPLC080C16MP12	21.0	CM37CE2A1	High	1200	34.8	26.2	17.25	12.75
				Med	600	18.5	14.2	–	17.00
				Low	475	11.3	10.0	–	31.25
YXV36B21S	YPLC100C16MP12	21.0	CM37CE2A1	High	1200	34.8	26.2	17.25	12.75
				Med	600	18.5	14.2	–	17.00
				Low	475	11.3	10.0	–	31.25
YXV48B21S	TM8V100C20MP11	21.0	CM49CE3A1	High	1550	45.0	32.8	19.00	12.50
				Med	850	25.2	19.9	–	18.80
				Low	600	14.6	12.9	–	33.80
YXV48B21S	TM8V120C20MP11	21.0	CM49CE3A1	High	1550	45.0	32.8	19.00	12.50
				Med	850	25.2	19.9	–	18.80
				Low	600	14.6	12.9	–	33.80
YXV48B21S	TM9V080C16MP11	21.0	CM49CE3A1	High	1600	45.0	33.2	18.75	12.20
				Med	800	25.0	19.3	–	18.65
				Low	450	14.0	11.0	–	33.90
YXV48B21S	TM9V100C16MP11	21.0	CM49CE3A1	High	1600	45.0	33.2	18.75	12.20
				Med	800	25.0	19.3	–	18.65
				Low	450	14.0	11.0	–	33.90
YXV48B21S	TM9V100C20MP11	21.0	CM49CE3A1	High	1650	45.0	33.6	18.50	12.20
				Med	675	24.4	17.8	–	18.45
				Low	350	13.5	9.7	–	33.35
YXV48B21S	TM9V120D20MP11	24.5	CM49DE3A1	High	1575	45.0	33.0	18.25	12.25
				Med	1000	25.8	22.0	–	18.25
				Low	725	14.8	11.4	–	32.80
YXV48B21S	TMLV100C20MP11	21.0	CM49CE3A1	High	1550	45.0	32.8	19.00	12.50
				Med	850	25.2	19.9	–	18.80
				Low	600	14.6	12.9	–	33.80
YXV48B21S	TMLV120C20MP11	21.0	CM49CE3A1	High	1550	45.0	32.8	19.00	12.50
				Med	850	25.2	19.9	–	18.80
				Low	600	14.6	12.9	–	33.80
YXV48B21S	TP9C080C16MP12	21.0	CM49CE3A1	High	1600	45.0	33.2	18.75	12.20
				Med	800	25.0	19.3	–	18.65
				Low	450	14.0	11.0	–	33.90
YXV48B21S	TP9C100C16MP12	21.0	CM49CE3A1	High	1600	45.0	33.2	18.75	12.20
				Med	800	25.0	19.3	–	18.65
				Low	450	14.0	11.0	–	33.90

Continued on next page.

COOLING CAPACITY - With High Efficiency Motor Furnaces¹ (Continued)

UNIT MODEL	FURNACE		COIL MODEL ²	STAGE	COOLING				
	MODEL	WIDTH			RATED CFM	NET MBH		SEER	EER
						TOTAL	SENS.		
YXV48B21S	TP9C100C20MP12	21.0	CM49CE3A1	High	1650	45.0	33.6	18.50	12.20
				Med	675	24.4	17.8	–	18.45
				Low	350	13.5	9.7	–	33.35
YXV48B21S	TP9C120D20MP12	24.5	CM49DE3A1	High	1575	45.0	33.0	18.25	12.25
				Med	1000	25.8	22.0	–	18.25
				Low	725	14.8	11.4	–	32.80
YXV48B21S	TPLC100C20MP12	21.0	CM49CE3A1	High	1550	45.0	32.8	19.00	12.50
				Med	850	25.2	19.9	–	18.80
				Low	600	14.6	12.9	–	33.80
YXV48B21S	TPLC120C20MP12	21.0	CM49CE3A1	High	1550	45.0	32.8	19.00	12.50
				Med	850	25.2	19.9	–	18.80
				Low	600	14.6	12.9	–	33.80
YXV48B21S	YP9C080C16MP12	21.0	CM49CE3A1	High	1600	45.0	33.2	18.75	12.20
				Med	800	25.0	19.3	–	18.65
				Low	450	14.0	11.0	–	33.90
YXV48B21S	YP9C100C16MP12	21.0	CM49CE3A1	High	1600	45.0	33.2	18.75	12.20
				Med	800	25.0	19.3	–	18.65
				Low	450	14.0	11.0	–	33.90
YXV48B21S	YP9C100C20MP12	21.0	CM49CE3A1	High	1650	45.0	33.6	18.50	12.20
				Med	675	24.4	17.8	–	18.45
				Low	350	13.5	9.7	–	33.35
YXV48B21S	YP9C120D20MP12	24.5	CM49DE3A1	High	1575	45.0	33.0	18.25	12.25
				Med	1000	25.8	22.0	–	18.25
				Low	725	14.8	11.4	–	32.80
YXV48B21S	YPLC100C20MP12	21.0	CM49CE3A1	High	1550	45.0	32.8	19.00	12.50
				Med	850	25.2	19.9	–	18.80
				Low	600	14.6	12.9	–	33.80
YXV48B21S	YPLC120C20MP12	21.0	CM49CE3A1	High	1550	45.0	32.8	19.00	12.50
				Med	850	25.2	19.9	–	18.80
				Low	600	14.6	12.9	–	33.80
YXV60B21S	TM8V100C20MP11	21.0	CM61CE4A1	High	1625	52.5	37.4	19.00	12.50
				Med	1025	29.6	23.8	–	18.40
				Low	775	20.8	17.4	–	34.80
YXV60B21S	TM8V120C20MP11	21.0	CM61CE4A1	High	1625	52.5	37.4	19.00	12.50
				Med	1025	29.6	23.8	–	18.40
				Low	775	20.8	17.4	–	34.80
YXV60B21S	TM9V100C20MP11	21.0	CM61CE4A1	High	1725	52.5	37.8	19.00	12.20
				Med	900	29.2	22.2	–	18.40
				Low	575	19.9	14.8	–	34.80
YXV60B21S	TM9V120D20MP11	24.5	CM61DE4A1	High	1725	52.5	37.8	18.75	12.25
				Med	1150	30.0	25.2	–	18.20
				Low	900	20.8	18.6	–	34.00
YXV60B21S	TMLV100C20MP11	21.0	CM61CE4A1	High	1625	52.5	37.4	19.00	12.50
				Med	1025	29.6	23.8	–	18.40
				Low	775	20.8	17.4	–	34.80
YXV60B21S	TMLV120C20MP11	21.0	CM61CE4A1	High	1625	52.5	37.4	19.00	12.50
				Med	1025	29.6	23.8	–	18.40
				Low	775	20.8	17.4	–	34.80
YXV60B21S	TP9C100C20MP12	21.0	CM61CE4A1	High	1725	52.5	37.8	19.00	12.20
				Med	900	29.2	22.2	–	18.40
				Low	575	19.9	14.8	–	34.80

Continued on next page.

COOLING CAPACITY - With High Efficiency Motor Furnaces¹ (Continued)

UNIT MODEL	FURNACE		COIL MODEL ²	STAGE	COOLING				
	MODEL	WIDTH			RATED CFM	NET MBH		SEER	EER
						TOTAL	SENS.		
YXV60B21S	TP9C120D20MP12	24.5	CM61DE4A1	High	1725	52.5	37.8	18.75	12.25
				Med	1150	30.0	25.2	–	18.20
				Low	900	20.8	18.6	–	34.00
YXV60B21S	TPLC100C20MP12	21.0	CM61CE4A1	High	1625	52.5	37.4	19.00	12.50
				Med	1025	29.6	23.8	–	18.40
				Low	775	20.8	17.4	–	34.80
YXV60B21S	TPLC120C20MP12	21.0	CM61CE4A1	High	1625	52.5	37.4	19.00	12.50
				Med	1025	29.6	23.8	–	18.40
				Low	775	20.8	17.4	–	34.80
YXV60B21S	YP9C100C20MP12	21.0	CM61CE4A1	High	1725	52.5	37.8	19.00	12.20
				Med	900	29.2	22.2	–	18.40
				Low	575	19.9	14.8	–	34.80
YXV60B21S	YP9C120D20MP12	24.5	CM61DE4A1	High	1725	52.5	37.8	18.75	12.25
				Med	1150	30.0	25.2	–	18.20
				Low	900	20.8	18.6	–	34.00
YXV60B21S	YPLC100C20MP12	21.0	CM61CE4A1	High	1625	52.5	37.4	19.00	12.50
				Med	1025	29.6	23.8	–	18.40
				Low	775	20.8	17.4	–	34.80
YXV60B21S	YPLC120C20MP12	21.0	CM61CE4A1	High	1625	52.5	37.4	19.00	12.50
				Med	1025	29.6	23.8	–	18.40
				Low	775	20.8	17.4	–	34.80

For rated condition information, see the footnotes below the System Capacity - Single Piece and Modular Air Handlers table.

1. High Efficiency Motor Furnaces have B.O.D (Blower Off Delay) standard.
2. CM coils available with a factory installed horizontal drain pan. See price pages for specific model number.

APPLICATION & ACCESSORIES

Refer to Price Manual for specific model numbers.

Support Feet S1-HPRKIT-:** Kit of 5 support feet to raise unit above snow or landscaping. Available in heights of 3", 6" or 12".

Anchor Bracket Kit S1-1HK0401: Firmly anchors unit to pad or support structure. When properly installed, approved for ground-mounted or roof-mounted applications.

Wall Mount Kit (S1-ACB-):** Includes two brackets to allow outdoor unit to be securely mounted to a vertical wall. Mounting hardware is field sourced according to the specific application.

Winter Cover Kit S1-CCVRE**:** Custom fit winter cover protects AC condensing unit from debris during the off-season. Must be removed prior to unit operation. See Price Pages or Source1 SmartSearch for the correct cover for each application

Touch-up Paint S1-5130153**:** Color matched aerosol paint for touching up unit chassis and panels. See Price Pages or Source1 SmartSearch for the correct color for each application.

Thermostat: These advanced, communicating, variable capacity designs require the York Hx™ Touchscreen Thermostat (S1-THXU280) available through Source1. For more information, see the thermostat section of the Product Equipment Catalog.

SOUND POWER RATINGS - COOLING

High Stage Cooling		Octave Band Sound Power Level (db re. 1-pW)								
Model Numbers	63	125	250	500	1000	2000	4000	8000	dBA	SQI
YXV24B21S	67	69	65	68	63	59	57	53	69	19.1
YXV36B21S	71	75	69	71	69	65	59	53	73	19.1
YXV48B21S	72	73	71	71	69	64	59	54	73	19.2
YXV60B21S	75	76	73	72	70	65	61	55	74	19.0
Low Stage Cooling		Octave Band Sound Power Level (db re. 1-pW)								
Model Numbers	63	125	250	500	1000	2000	4000	8000	dBA	SQI
YXV24B21S	63	64	52	49	46	42	33	36	53	19.0
YXV36B21S	63	64	55	59	55	50	42	37	60	19.1
YXV48B21S	64	64	72	53	50	42	36	35	64	19.1
YXV60B21S	64	65	59	56	54	49	42	38	59	19.1

Rated in accordance with ARI Standard 270.

UNIT OPERATION

COOLING OPERATION

During cooling operation, the main outdoor control will receive a communicated demand signal along with the current space temperature and setpoint. The control algorithm will then utilize these signals to communicate the proper compressor speed, OD fan speed, and ID blower CFM to match system output for the required space load.

EMERGENCY HEAT

Emergency Heating mode is defined as a compressor speed reference of zero and the backup heat source energized. In other words, a 'W' signal present without any 'Y' signals present. The control energizes 'W1 OUT' immediately when an emergency heat signal "W" is received. The control energizes "W2 OUT" based upon the stage delay setting in the thermostat (default 120 minutes) after the "W1 OUT" output is energized.

During emergency heating mode, the control returns to standby mode. The control passes the "W1 OUT" back to the ID unit automatically if no "Y" is present.

MECHANICAL SPECIFICATIONS

MANUFACTURE AND CERTIFICATIONS

- Units shall be manufactured in an ISO 9001 certified facility.
- Units shall be certified by CSA to UL 1995 / CSA 22.2 and performance certified to ANSI/AHRI Standard 210/240.
- Units shall be sound tested according to ANSI/AHRI Standard 270.
- Certified matched system ratings will be available for download from the AHRI online directory at www.ahridirectory.org.
- Unit packaging shall be marked, "Assembled in the USA".
- Unit shall be labeled with the ENERGY STAR logo.
- Unit shall be recognized as ENERGY STAR Most Efficient. (May apply only to select models in each series).

UNIT APPLICATION

- Units shall be approved for cooling operation between 35°F and 125°F without modification.
- Units shall be approved for linesets up to 80 feet equivalent length without modification.
- Units shall be approved for installation within 6 inches of a flat vertical wall without modification, according to the instructions in the technical literature.
- Units shall be certified to the 5th Edition (2014) of the Florida Building Code for both Ground Mounted and Rooftop Mounted applications up to 200 feet above grade with approved mounting kit.

UNIT ACCESS

- Units shall have a removable fan guard that can be removed independently of the top for interior access through the top of the unit without damaging the coil.
- Units shall have two removable stamped steel coil guards for exterior coil access.
- Units shall have a separate compartment for electrical controls that can be accessed without disturbing the unit airflow.
- Units shall have a blockoff panel that can be removed to provide interior unit access through the side of the unit.
- Units shall have a removable blockoff panel and a swing away removable electrical panel that provides sufficient interior unit access for removing the compressor through the side of the unit.

UNIT CONSTRUCTION

- Units shall be shipped completely wired, piped and assembled. Wiring pigtails shall be provided for field control wiring connections. Service valves shall be provided for field refrigerant line connections.

- Units shall be factory leak checked, run tested, and shipped with a holding charge of R-410A refrigerant.
- Unit cabinet components shall be G90 equivalent steel finished with powder-coat paint rated at a minimum of 1,000 hours under ASTM B117 testing.
- Unit shall be constructed with a composite base pan to prevent corrosion and minimize noise and vibration.
- Units shall have a single corner post opposite the electrical control box and two independently removable steel coil guard panels to optimize cabinet strength and serviceability.
- Units shall have L-shaped stamped sheet metal coil guards with extruded louvers for maximum panel durability and system protection.
- Units shall have a factory installed filter-drier for faster installation and improved system reliability.
- Unit base valves shall be mounted diagonally on the unit base pan with service ports that provide sufficient clearance for low-loss hose fittings.
- Units shall be constructed with a high pressure switch and a low pressure for system protection.
- Units shall be constructed with all badging and labels applied at the factory.

UNIT COMPONENTS

- Compressor shall be hermetic with internal electrical overload protection and internal overpressure protection.
- Compressor shall be mounted on rubber vibration isolators that do not require the removal of transportation clips or brackets.
- Units shall be constructed using a scroll compressor paired with an inverter drive.
- Condenser fan shall be direct drive with vertical air discharge for low sound levels.
- Condenser fan blades shall be swept-wing to minimize sound.
- Condenser fan motor shall be ECM construction with permanently lubricated ball bearing motors approved for vertical shaft applications.
- Condenser coil shall be air cooled and constructed of enhanced aluminum fins mechanically bonded to internally enhanced Ø 7mm copper tubing.

UNIT WARRANTIES

- Unit manufacturer shall provide a Limited Lifetime compressor warranty with unit registration.
- Unit manufacturer shall provide a limited 5-Year parts warranty extended to 10 years with registration.

TYPICAL INSTALLATION

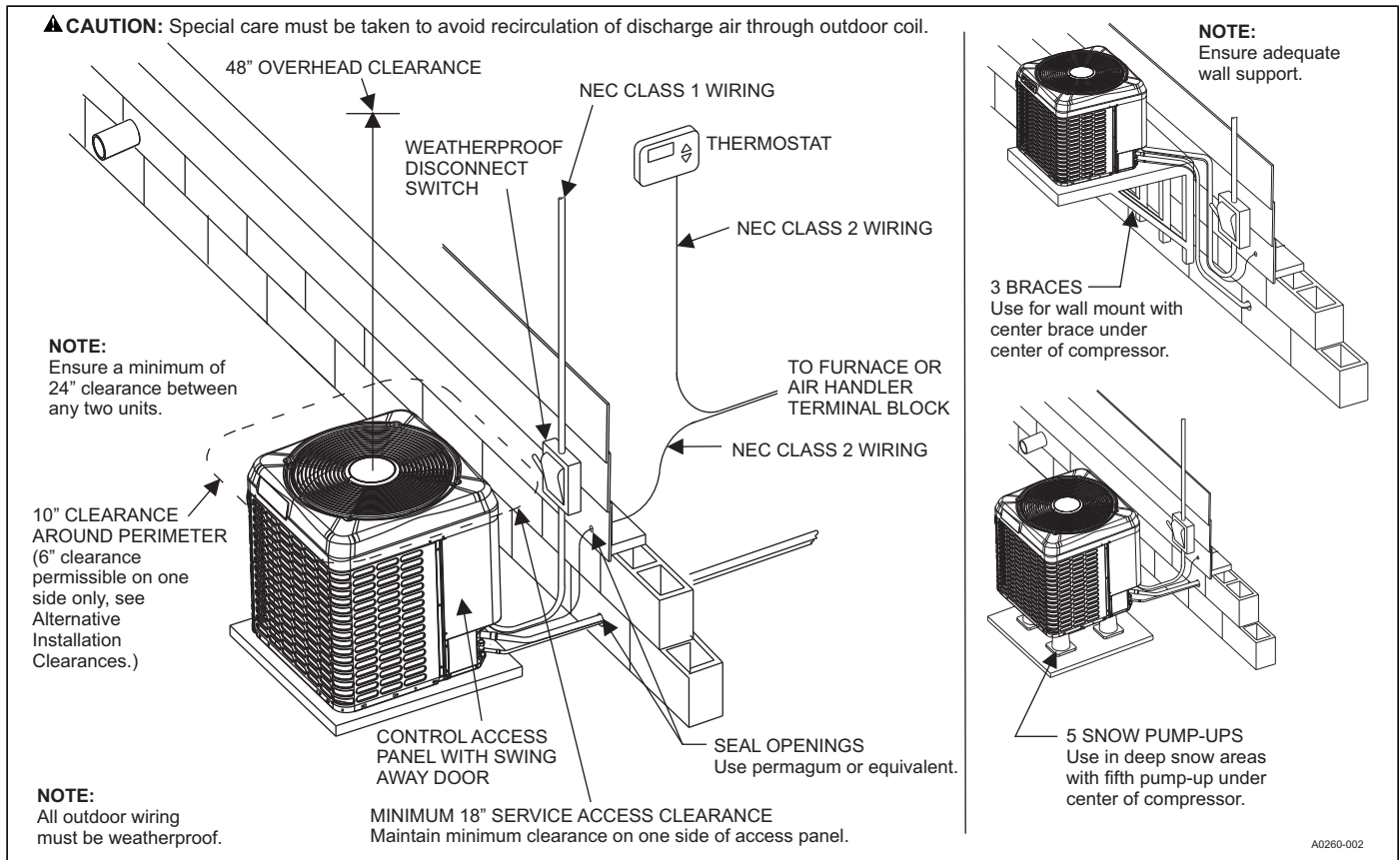

▲ CAUTION

Care must be taken to prevent ice from damaging the unit. Damage may occur from ice falling onto unit from a sloped roof or from a vertical drip line due to a partial overhang.

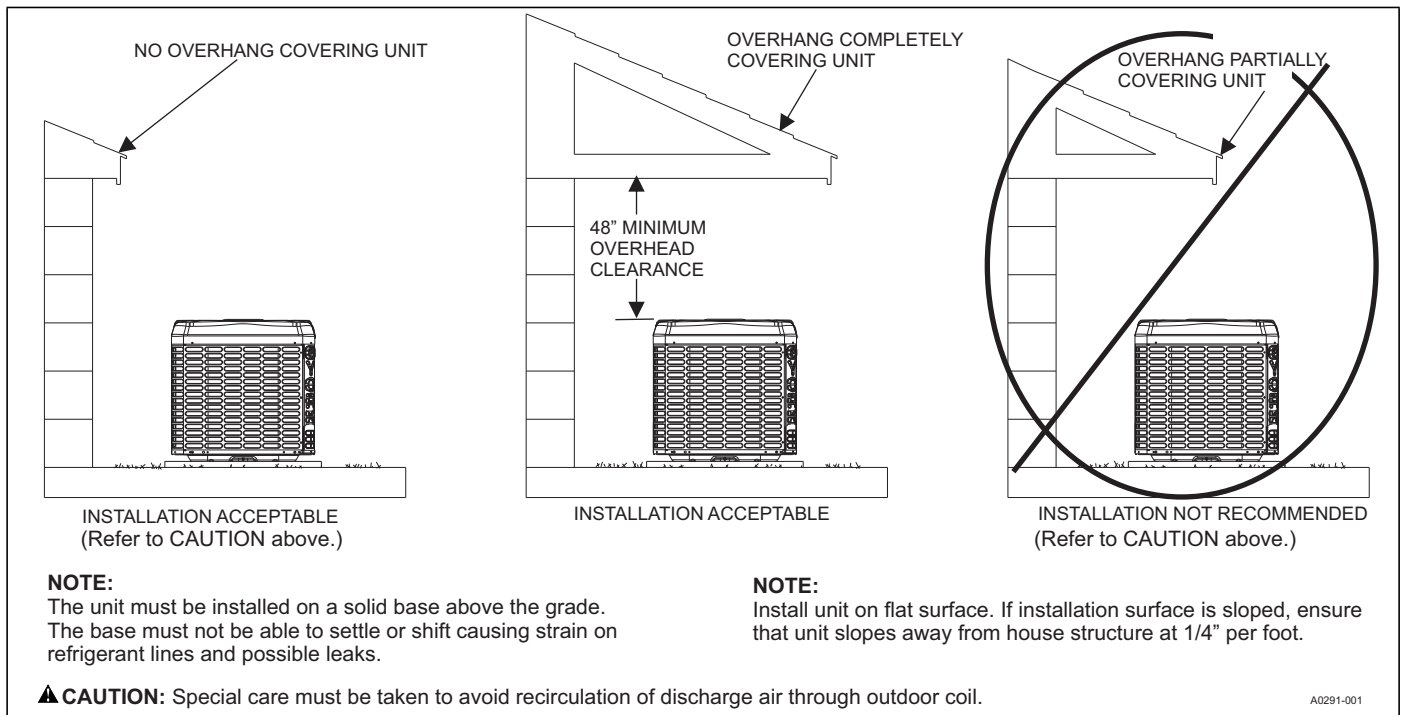

TYPICAL FIELD WIRING

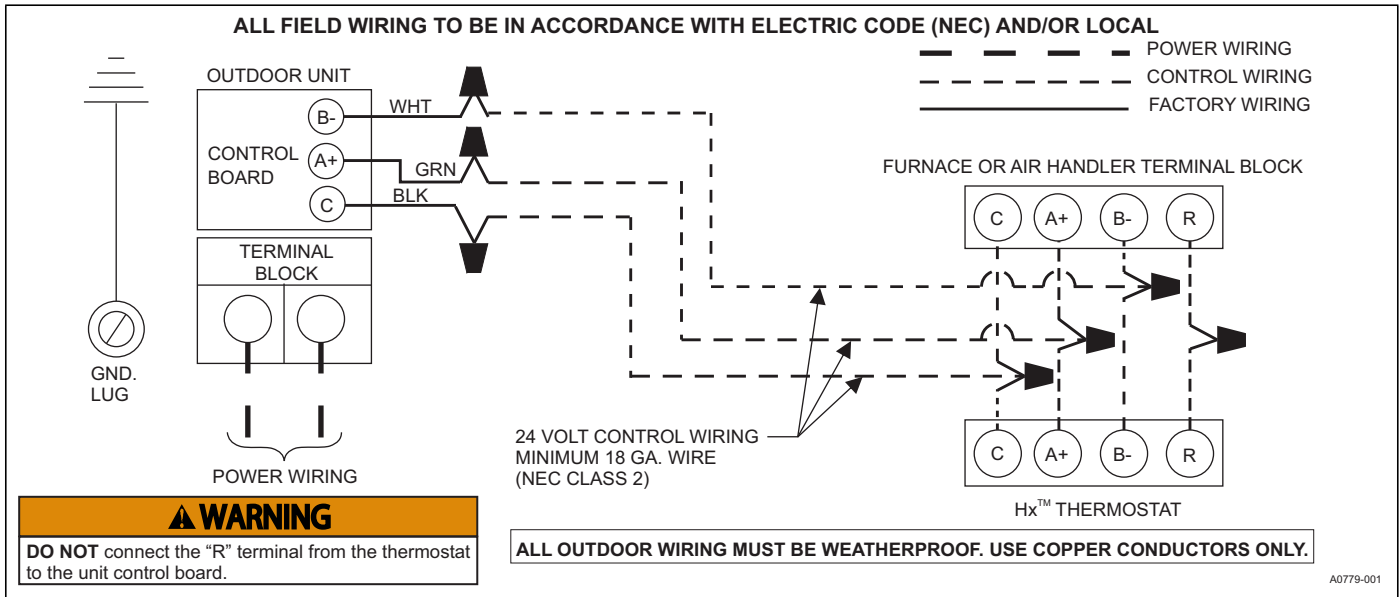

ALTERNATIVE INSTALLATION CLEARANCES

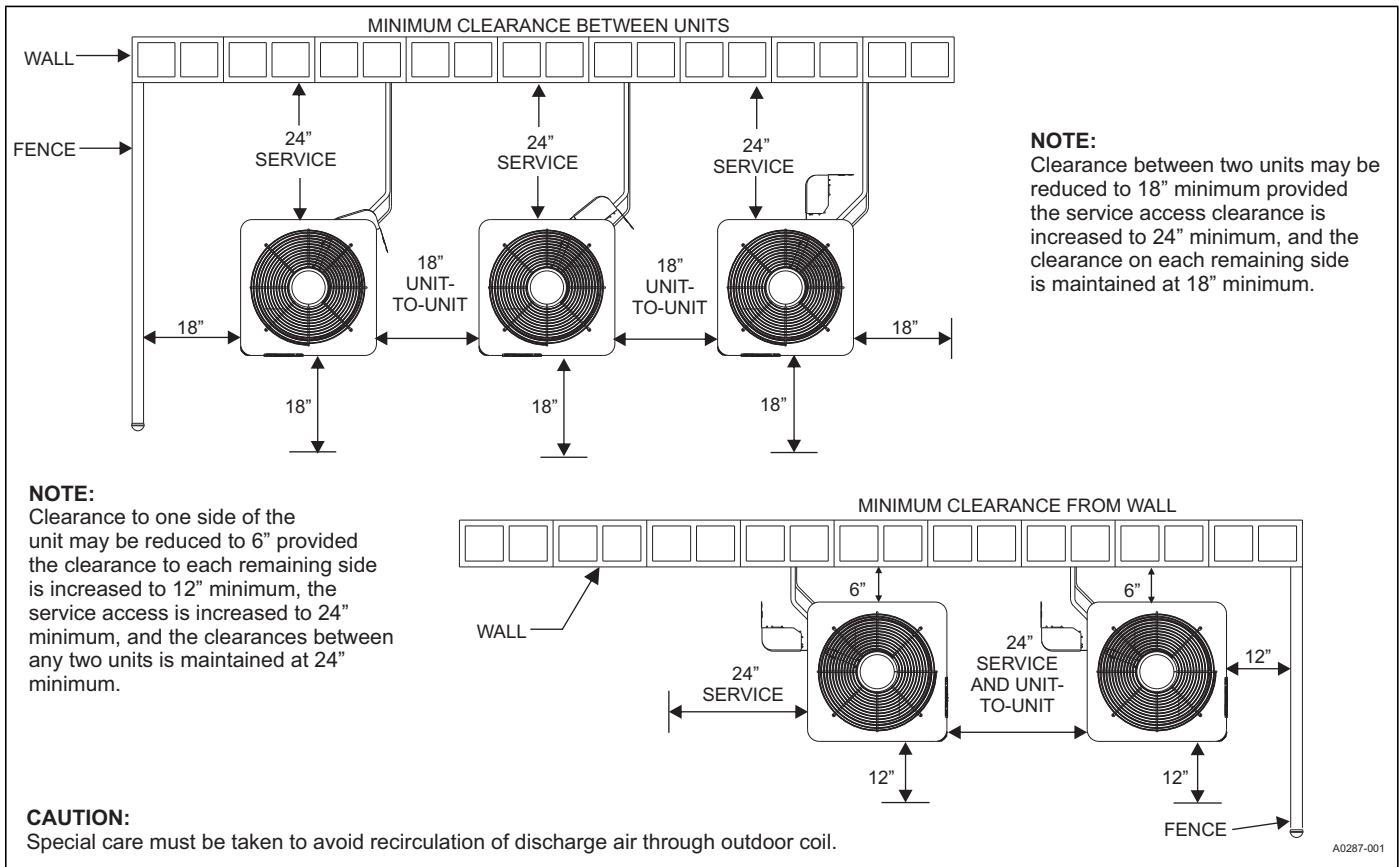

PERFORMANCE DATA - 2 TON

NOTICE

Outdoor units must be applied with Johnson Controls Unitary Products indoor coils, so Condenser Only data is not provided.

COOLING PERFORMANCE DATA- HIGH																
AIR CONDITIONER MODEL NO.		YXV24B21S														
AIR TEMP. ENTERING OUTDOOR UNIT (°F)	IDCFM	680					780					880				
	ID DB (°F)	80	80	75	80	80	80	80	75	80	80	80	80	75	80	80
	ID WB (°F)	57	62	62	67	72	57	62	62	67	72	57	62	62	67	72
55	T.C.	19.3	20.0	21.1	22.9	25.7	19.3	20.2	21.15	23.5	26.75	19.3	20.4	21.2	24.1	27.8
	S.C.	13.4	14.1	14.3	15.7	17.7	13.45	14.25	14.4	16.05	18.15	13.5	14.4	14.5	16.4	18.6
	KW	1.08	1.07	1.03	1.00	0.94	1.04	1.11	1.06	1.03	0.98	1.00	1.14	1.09	1.06	1.01
65	T.C.	19.5	20.4	21.2	23.4	26.4	19.6	20.7	21.6	24.0	27.2	19.8	21.1	22.1	24.6	28.1
	S.C.	13.5	14.3	14.4	15.9	17.9	13.7	14.5	14.7	16.3	18.3	13.9	14.7	14.9	16.6	18.7
	KW	1.21	1.20	1.18	1.16	1.11	1.20	1.24	1.21	1.18	1.14	1.20	1.27	1.25	1.21	1.17
75	T.C.	19.7	20.7	21.3	23.8	27.0	20.0	21.3	22.1	24.4	27.7	20.2	21.8	22.9	25.0	28.4
	S.C.	13.6	14.4	14.5	16.1	18.0	13.9	14.7	14.9	16.5	18.4	14.2	15.0	15.3	16.8	18.8
	KW	1.35	1.34	1.34	1.31	1.27	1.37	1.36	1.37	1.34	1.30	1.40	1.39	1.40	1.37	1.33
85	T.C.	19.9	21.1	21.4	24.3	27.1	20.4	21.8	22.3	24.9	28.0	20.9	22.5	23.2	25.5	29.0
	S.C.	13.7	14.6	14.6	16.3	18.1	14.1	14.9	15.0	16.7	18.6	14.6	15.3	15.5	17.0	19.1
	KW	1.62	1.61	1.61	1.60	1.57	1.65	1.64	1.65	1.63	1.60	1.68	1.68	1.68	1.66	1.63
95	T.C.	20.0	21.5	21.5	24.7	27.1	20.8	22.4	22.5	25.3	28.3	21.6	23.2	23.4	25.9	29.5
	S.C.	13.8	14.7	14.7	16.5	18.1	14.4	15.2	15.2	16.9	18.7	14.9	15.6	15.6	17.2	19.3
	KW	1.89	1.89	1.89	1.88	1.86	1.93	1.92	1.92	1.91	1.89	1.96	1.96	1.96	1.94	1.93
105	T.C.	20.2	21.9	21.6	25.2	27.2	21.2	22.9	22.6	25.8	28.6	22.3	23.9	23.7	26.4	30.1
	S.C.	13.9	14.9	14.8	16.7	18.2	14.6	15.4	15.3	17.1	18.9	15.3	15.9	15.8	17.4	19.6
	KW	2.39	2.39	2.39	2.38	2.37	2.43	2.42	2.42	2.41	2.41	2.47	2.46	2.45	2.45	2.44
115	T.C.	20.3	22.3	21.7	25.6	27.2	21.7	23.5	22.8	26.2	28.9	23.0	24.6	23.9	26.8	30.6
	S.C.	14.0	15.0	14.9	16.9	18.2	14.8	15.6	15.4	17.3	19.0	15.6	16.2	15.9	17.6	19.8
	KW	2.88	2.87	2.87	2.86	2.86	2.92	2.91	2.90	2.90	2.90	2.96	2.94	2.93	2.94	2.94
125	T.C.	20.5	22.7	21.8	26.1	27.3	22.1	24.0	23.0	26.7	29.2	23.7	25.3	24.2	27.3	31.2
	S.C.	14.1	15.2	15.0	17.1	18.3	15.0	15.8	15.5	17.5	19.2	16.0	16.5	16.1	17.8	20.1
	KW	3.36	3.35	3.35	3.35	3.36	3.41	3.39	3.38	3.39	3.40	3.45	3.43	3.42	3.43	3.44

NOTE: ALL CAPACITIES INCLUDE INDOOR FAN HEAT. KW VALUES ARE FOR THE SYSTEM (OUTDOOR + INDOOR).

Green shaded cells are ACCA (TVA) conditions.

Blue shaded cells are AHRI conditions.

Multipliers for determining the performance with other indoor sections.

NOTE: For dry bulb temperatures different than those listed (between 73-87 °F), sensible capacity increases by 1060 BTUH per 1000 CFM per degree above the listed temperature and decreases by 1060 BTUH per 1000 CFM per degree below the listed temperature.

COIL MULTIPLIERS - 2 TON

Air Handler	Coil	T.C.	S.C.	KW
AVV25BE12	—	1.00	1.00	1.00
MVC12BN21	CM25BE1A1	1.00	1.05	1.00

FURNACE MULTIPLIERS - 2 TON

Furnaces	Coil	T.C.	S.C.	KW
TM9V060B12MP11	CM25BE1A1	0.95	0.90	0.98
TM9V080B12MP11	CM25BE1A1	0.95	0.90	0.98
TP9C060B12MP12	CM25BE1A1	0.95	0.90	0.98
TP9C080B12MP12	CM25BE1A1	0.95	0.90	0.98
YP9C060B12MP12	CM25BE1A1	0.95	0.90	0.98
YP9C080B12MP12	CM25BE1A1	0.95	0.90	0.98

PERFORMANCE DATA - 3 TON

NOTICE

Outdoor units must be applied with Johnson Controls Unitary Products indoor coils, so Condenser Only data is not provided.

COOLING PERFORMANCE DATA - HIGH

AIR CONDITIONER MODEL NO.		YXV36B21S														
AIR TEMP. ENTERING OUTDOOR UNIT (°F)	IDCFM	1020					1200					1320				
	ID DB (°F)	80	80	75	80	80	80	80	75	80	80	80	80	75	80	80
	ID WB (°F)	57	62	62	67	72	57	62	62	67	72	57	62	62	67	72
55	T.C.	29.6	30.1	32.1	34.9	36.4	29.4	30.9	33.2	35.4	37.0	29.1	31.6	34.2	35.9	37.5
	S.C.	20.0	20.7	21.4	23.3	24.0	20.1	21.0	21.95	23.5	24.2	20.2	21.3	22.5	23.7	24.4
	KW	1.42	1.40	1.40	1.38	1.38	1.46	1.45	1.45	1.43	1.44	1.49	1.49	1.50	1.49	1.49
65	T.C.	29.7	30.5	32.2	35.3	38.1	29.8	31.3	33.4	36.2	38.8	30.0	32.2	34.5	37.2	39.5
	S.C.	20.1	20.9	21.5	23.5	25.1	20.4	21.2	22.0	23.9	25.4	20.7	21.6	22.6	24.3	25.7
	KW	1.72	1.71	1.71	1.69	1.66	1.76	1.76	1.76	1.74	1.71	1.81	1.81	1.81	1.79	1.76
75	T.C.	29.8	30.9	32.3	35.6	39.8	30.3	31.8	33.6	37.1	40.6	30.8	32.7	34.8	38.5	41.4
	S.C.	20.2	21.0	21.5	23.6	26.1	20.7	21.5	22.1	24.3	26.5	21.1	21.9	22.6	24.9	26.9
	KW	2.02	2.02	2.02	2.00	1.93	2.07	2.07	2.07	2.05	1.98	2.12	2.12	2.12	2.10	2.04
85	T.C.	29.9	31.3	32.4	35.7	40.0	30.8	32.3	33.8	37.7	41.7	31.7	33.3	35.1	39.8	43.4
	S.C.	20.3	21.2	21.6	23.8	26.3	20.9	21.7	22.1	24.6	27.2	21.6	22.2	22.6	25.5	28.2
	KW	2.42	2.43	2.43	2.43	2.40	2.48	2.48	2.49	2.45	2.42	2.53	2.53	2.54	2.48	2.45
95	T.C.	30.0	31.7	32.5	35.7	40.2	31.3	32.8	34.0	38.4	42.8	32.5	33.8	35.4	41.1	45.3
	S.C.	20.4	21.3	21.6	23.9	26.4	21.2	21.9	22.1	25.0	27.9	22.0	22.5	22.6	26.1	29.4
	KW	2.82	2.84	2.84	2.85	2.86	2.88	2.89	2.90	2.85	2.87	2.94	2.95	2.96	2.86	2.87
105	T.C.	30.1	31.8	32.6	35.8	40.4	31.4	32.9	34.2	39.1	43.8	32.7	33.9	35.7	42.4	47.3
	S.C.	20.5	21.4	21.7	24.0	26.6	21.3	22.0	22.2	25.4	28.6	22.1	22.6	22.7	26.7	30.7
	KW	3.54	3.56	3.56	3.59	3.62	3.61	3.62	3.62	3.61	3.64	3.67	3.68	3.68	3.64	3.67
115	T.C.	30.2	32.0	32.7	36.0	40.5	31.5	33.0	34.4	39.8	44.9	32.8	34.0	36.0	43.7	49.2
	S.C.	20.6	21.5	21.8	24.1	26.7	21.4	22.1	22.3	25.7	29.3	22.3	22.7	22.9	27.3	31.9
	KW	4.24	4.26	4.26	4.30	4.35	4.31	4.32	4.32	4.35	4.40	4.38	4.38	4.39	4.40	4.44
125	T.C.	30.3	32.1	32.8	36.1	40.7	31.7	33.1	34.6	40.6	45.9	33.0	34.1	36.3	45.0	51.2
	S.C.	20.7	21.6	21.9	24.2	26.9	21.6	22.2	22.5	26.1	30.0	22.4	22.8	23.0	27.9	33.2
	KW	4.93	4.95	4.96	5.01	5.08	5.01	5.02	5.03	5.08	5.15	5.09	5.09	5.09	5.16	5.22

NOTE: ALL CAPACITIES INCLUDE INDOOR FAN HEAT. KW VALUES ARE FOR THE SYSTEM (OUTDOOR + INDOOR).

Green shaded cells are ACCA (TVA) conditions.

Blue shaded cells are AHRI conditions.

Multipliers for determining the performance with other indoor sections.

NOTE: For dry bulb temperatures different than those listed (between 73-87 °F), sensible capacity increases by 1060 BTUH per 1000 CFM per degree above the listed temperature and decreases by 1060 BTUH per 1000 CFM per degree below the listed temperature.

COIL MULTIPLIERS - 3 TON

Air Handler	Coil	T.C.	S.C.	KW
AVV37CE22	–	1.00	1.00	1.00
AVV37BE22	–	1.00	1.09	1.14
MVC12BN21	CM37BE2A1	1.00	1.09	1.14
MVC16CN21	CM37CE2A1	1.01	1.12	1.12

FURNACE MULTIPLIERS - 3 TON

Furnaces	Coil	T.C.	S.C.	KW
TM9V060B12MP11	CM37BE2A1	0.94	0.85	1.10
TM9V080B12MP11	CM37BE2A1	0.94	0.85	1.10
YP9C060B12MP12	CM37BE2A1	0.94	0.85	1.10
YP9C080B12MP12	CM37BE2A1	0.94	0.85	1.10
TM8V080C16MP11	CM37CE2A1	1.01	1.12	1.14

FURNACE MULTIPLIERS - 3 TON (Continued)

Furnaces	Coil	T.C.	S.C.	KW
TM8V100C16MP11	CM37CE2A1	1.01	1.12	1.14
TM9V080C16MP11	CM37CE2A1	0.98	1.01	1.14
TM9V100C16MP11	CM37CE2A1	0.98	1.01	1.14
TMLV080C16MP11	CM37CE2A1	1.01	1.12	1.14
TMLV100C16MP11	CM37CE2A1	1.01	1.12	1.14
TP9C080C16MP12	CM37CE2A1	0.98	1.01	1.14
TP9C100C16MP12	CM37CE2A1	0.98	1.01	1.14
TPLC080C16MP12	CM37CE2A1	1.01	1.12	1.14
TPLC100C16MP12	CM37CE2A1	1.01	1.12	1.14
YP9C080C16MP12	CM37CE2A1	0.98	1.01	1.14
YP9C100C16MP12	CM37CE2A1	0.98	1.01	1.14
YPLC080C16MP12	CM37CE2A1	1.01	1.12	1.14
YPLC100C16MP12	CM37CE2A1	1.01	1.12	1.14

PERFORMANCE DATA - 4 TON

NOTICE

Outdoor units must be applied with Johnson Controls Unitary Products indoor coils, so Condenser Only data is not provided.

COOLING PERFORMANCE DATA - HIGH																
AIR CONDITIONER MODEL NO.		YXV48B21S														
AIR TEMP. ENTERING OUTDOOR UNIT (°F)	IDCFM	1360					1560					1760				
	ID DB (°F)	80	80	75	80	80	80	80	75	80	80	80	80	75	80	80
	ID WB (°F)	57	62	62	67	72	57	62	62	67	72	57	62	62	67	72
55	T.C.	40.4	42	42.1	45	45.5	42.4	42.9	43.0	45.0	45.4	44.4	43.8	43.9	44.9	45.3
	S.C.	27.2	28.1	28.0	30.0	30.3	29.0	28.8	28.7	30.0	30.2	30.8	29.4	29.3	30.0	30.1
	KW	2.10	1.85	1.85	1.82	1.81	2.16	1.91	1.92	1.89	1.89	2.22	1.97	1.98	1.96	1.96
65	T.C.	40.8	42.3	42.5	46.1	49.1	42.7	43.3	43.3	46.5	49.2	44.6	44.2	44.2	46.9	49.3
	S.C.	27.5	28.4	28.4	30.8	32.7	29.2	29.1	29.0	31.1	32.7	30.9	29.8	29.6	31.4	32.8
	KW	2.40	2.27	2.27	2.25	2.23	2.46	2.34	2.34	2.32	2.31	2.53	2.40	2.41	2.39	2.38
75	T.C.	41.1	42.6	42.8	47.2	52.6	43.0	43.6	43.6	48.0	53.0	44.8	44.6	44.4	48.8	53.3
	S.C.	27.8	28.7	28.7	31.6	35.0	29.4	29.4	29.3	32.2	35.3	31.0	30.1	29.8	32.7	35.5
	KW	2.70	2.69	2.69	2.68	2.65	2.76	2.76	2.77	2.75	2.73	2.83	2.83	2.84	2.82	2.80
85	T.C.	41.5	42.9	43.2	47.7	52.9	43.2	43.9	44.0	48.5	53.6	45.0	45.0	44.8	49.3	54.2
	S.C.	28.1	29.0	29.1	32.0	35.4	29.6	29.7	29.6	32.6	35.8	31.1	30.4	30.1	33.2	36.3
	KW	3.28	3.29	3.29	3.29	3.30	3.35	3.36	3.36	3.37	3.37	3.43	3.43	3.44	3.44	3.45
95	T.C.	41.8	43.2	43.5	48.1	53.2	43.5	44.3	44.3	48.9	54.2	45.1	45.3	45.1	49.7	55.1
	S.C.	28.4	29.3	29.4	32.4	35.8	29.8	30.0	29.9	33.0	36.4	31.2	30.7	30.4	33.6	37.0
	KW	3.86	3.88	3.88	3.91	3.94	3.94	3.96	3.96	3.99	4.02	4.03	4.04	4.04	4.07	4.10
105	T.C.	41.5	43.2	43.5	47.5	55.8	43.1	43.9	44.3	48.3	54.7	44.6	44.6	45.0	49.0	53.5
	S.C.	28.3	29.3	29.4	32.3	38.3	29.4	29.9	29.9	32.9	37.6	30.5	30.4	30.3	33.4	36.9
	KW	4.58	4.60	4.60	4.65	4.72	4.67	4.68	4.68	4.73	4.79	4.76	4.77	4.76	4.82	4.85
115	T.C.	41.3	43.0	42.7	46.9	52.4	42.7	43.5	43.8	47.6	52.2	44.1	43.9	44.9	48.3	51.9
	S.C.	28.2	29.3	29.4	32.2	36.6	29.0	29.7	29.8	32.7	36.7	29.8	30.1	30.2	33.2	36.8
	KW	5.62	5.64	5.64	5.72	5.81	5.72	5.74	5.74	5.82	5.89	5.83	5.83	5.83	5.92	5.98
125	T.C.	37.3	38.0	38.1	41.2	45.8	38.6	38.9	38.8	41.9	46.5	39.8	39.8	39.5	42.5	47.2
	S.C.	25.9	26.4	26.3	28.4	31.5	26.7	27.1	26.8	28.9	32.0	27.4	27.8	27.3	29.4	32.5
	KW	5.78	5.69	5.68	6.80	6.89	5.77	5.79	5.76	6.91	7.00	5.76	5.90	5.84	7.02	7.11

NOTE: ALL CAPACITIES INCLUDE INDOOR FAN HEAT. KW VALUES ARE FOR THE SYSTEM (OUTDOOR + INDOOR).

Green shaded cells are ACCA (TVA) conditions.

Blue shaded cells are AHRI conditions.

Multipliers for determining the performance with other indoor sections.

NOTE: For dry bulb temperatures different than those listed (between 73-87 °F), sensible capacity increases by 1060 BTUH per 1000 CFM per degree above the listed temperature and decreases by 1060 BTUH per 1000 CFM per degree below the listed temperature.

COIL MULTIPLIERS - 4 TON

Air Handler	Coil	T.C.	S.C.	KW
AVV49DE32	–	1.00	1.00	1.00
AVV49CE32	–	0.95	0.98	0.99
MVC16CN21	CM49CE3A1	0.95	0.98	0.99
MVC20DN21	CM49DE3A1	0.95	0.96	0.99

FURNACE MULTIPLIERS - 4 TON

Furnaces	Coil	T.C.	S.C.	KW
TM8V100C20MP11	CM49CE3A1	0.98	1.12	1.05
TM8V120C20MP11	CM49CE3A1	0.98	1.12	1.05
TM9V080C16MP11	CM49CE3A1	0.94	0.96	1.00
TM9V100C16MP11	CM49CE3A1	0.94	0.96	1.00
TM9V100C20MP11	CM49CE3A1	0.91	0.84	0.98
TM9V120D20MP11	CM49DE3A1	0.99	0.99	1.10

FURNACE MULTIPLIERS - 4 TON (Continued)

Furnaces	Coil	T.C.	S.C.	KW
TMLV100C20MP11	CM49CE3A1	0.98	1.12	1.05
TMLV120C20MP11	CM49CE3A1	0.98	1.12	1.05
TP9C080C16MP12	CM49CE3A1	0.94	0.96	1.00
TP9C100C16MP12	CM49CE3A1	0.94	0.96	1.00
TP9C100C20MP12	CM49CE3A1	0.91	0.84	0.98
TP9C120D20MP12	CM49DE3A1	0.99	0.99	1.13
TPLC100C20MP12	CM49CE3A1	0.98	1.12	1.05
TPLC120C20MP12	CM49CE3A1	0.98	1.12	1.05
YP9C080C16MP12	CM49CE3A1	0.94	0.96	1.00
YP9C100C16MP12	CM49CE3A1	0.94	0.96	1.00
YP9C100C20MP12	CM49CE3A1	0.91	0.84	0.98
YP9C120D20MP12	CM49DE3A1	0.99	0.99	1.13
YPLC100C20MP12	CM49CE3A1	0.98	1.12	1.05
YPLC120C20MP12	CM49CE3A1	0.98	1.12	1.05

PERFORMANCE DATA - 5 TON

NOTICE

Outdoor units must be applied with Johnson Controls Unitary Products indoor coils, so Condenser Only data is not provided.

COOLING PERFORMANCE DATA - HIGH

AIR CONDITIONER MODEL NO.		YXV60B21S														
AIR TEMP. ENTERING OUTDOOR UNIT (°F)	IDCFM	1530					1800					1980				
	ID DB (°F)	80	80	75	80	80	80	80	75	80	80	80	80	75	80	80
	ID WB (°F)	57	62	62	67	72	57	62	62	67	72	57	62	62	67	72
55	T.C.	51.3	53.7	54.6	58.4	59.8	52.9	55.0	55.6	58.6	59.6	54.4	56.3	56.5	58.7	59.4
	S.C.	34.7	35.5	35.7	39.4	40.2	36.0	36.8	36.9	39.6	40.1	37.3	38.0	38.0	39.7	40.0
	KW	2.60	2.58	2.58	2.56	2.54	2.67	2.66	2.66	2.63	2.62	2.74	2.73	2.73	2.71	2.70
65	T.C.	51.3	53.8	54.6	58.9	62.7	53.0	55.1	55.6	59.5	62.9	54.7	56.4	56.6	60.2	63.1
	S.C.	34.7	36.1	36.3	40.1	42.4	36.1	37.2	37.3	40.5	42.6	37.5	38.2	38.3	41.0	42.8
	KW	3.13	3.13	3.13	3.13	3.13	3.21	3.22	3.22	3.21	3.22	3.30	3.30	3.30	3.29	3.31
75	T.C.	51.3	53.8	54.6	59.3	65.5	53.1	55.1	55.6	60.5	66.2	54.9	56.4	56.6	61.7	66.8
	S.C.	34.7	36.7	36.8	40.8	44.6	36.2	37.6	37.7	41.5	45.1	37.6	38.4	38.5	42.2	45.5
	KW	3.65	3.69	3.68	3.70	3.72	3.76	3.78	3.78	3.79	3.82	3.86	3.87	3.87	3.88	3.91
85	T.C.	51.3	53.9	54.7	59.8	65.5	53.2	55.2	55.7	60.8	66.5	55.1	56.5	56.7	61.8	67.5
	S.C.	35.3	37.3	37.4	41.3	45.3	36.6	38.2	38.2	42.0	45.9	37.9	39.0	39.0	42.8	46.6
	KW	4.49	4.52	4.52	4.56	4.60	4.59	4.62	4.62	4.65	4.69	4.69	4.71	4.71	4.75	4.79
95	T.C.	51.3	53.9	54.8	60.2	65.5	53.3	55.3	55.8	61.1	66.9	55.3	56.6	56.7	61.9	68.2
	S.C.	35.9	37.9	37.9	41.7	45.9	37.1	38.8	38.7	42.5	46.8	38.2	39.6	39.4	43.3	47.7
	KW	5.33	5.36	5.36	5.42	5.47	5.42	5.46	5.46	5.51	5.57	5.52	5.55	5.55	5.61	5.67
105	T.C.	47.6	49.8	50.1	55.5	61.3	49.5	51.0	51.1	56.6	62.7	51.4	52.2	52.1	57.6	64.0
	S.C.	34.1	35.6	35.8	39.5	43.3	35.5	36.5	36.5	40.2	44.2	36.8	37.3	37.2	40.8	45.1
	KW	5.90	5.94	5.94	6.00	6.08	6.01	6.04	6.03	6.10	6.17	6.12	6.14	6.13	6.20	6.27
115	T.C.	44.2	45.8	46.0	52.1	56.5	45.8	47.1	46.9	53.3	57.7	47.3	48.3	47.7	54.4	58.8
	S.C.	31.3	32.8	32.9	36.7	40.4	32.7	33.8	33.6	37.5	41.2	34.0	34.8	34.3	38.3	41.9
	KW	6.50	6.52	6.52	6.59	6.68	6.59	6.60	6.61	6.68	6.77	6.68	6.69	6.70	6.77	6.87
125	T.C.	39.5	41.8	41.4	46.7	52.2	41.1	42.9	42.5	47.5	53.1	42.6	44.0	43.6	48.2	53.9
	S.C.	28.4	30.1	30.4	33.7	37.4	29.7	31.0	31.0	34.3	38.0	30.9	31.9	31.6	34.8	38.6
	KW	7.15	7.21	7.19	7.27	7.34	7.24	7.29	7.28	7.36	7.43	7.34	7.37	7.36	7.45	7.52

NOTE: ALL CAPACITIES INCLUDE INDOOR FAN HEAT. KW VALUES ARE FOR THE SYSTEM (OUTDOOR + INDOOR).

Green shaded cells are ACCA (TVA) conditions.

Blue shaded cells are AHRI conditions.

Multipliers for determining the performance with other indoor sections.

NOTE: For dry bulb temperatures different than those listed (between 73-87 °F), sensible capacity increases by 1060 BTUH per 1000 CFM per degree above the listed temperature and decreases by 1060 BTUH per 1000 CFM per degree below the listed temperature.

COIL MULTIPLIERS - 5 TON

Air Handler	Coil	T.C.	S.C.	KW
AVV61DE42	-	1.00	1.00	1.00
AVV61CE42	-	1.00	0.96	1.02
MVC20DN21	CM61DE4A1	1.00	1.01	1.00

FURNACE MULTIPLIERS - 5 TON (Continued)

Furnaces	Coil	T.C.	S.C.	KW
TMLV100C20MP11	CM61CE4A1	1.00	0.97	1.04
TMLV120C20MP11	CM61CE4A1	1.00	0.97	1.04
TP9C100C20MP12	CM61CE4A1	1.00	0.98	1.07
TP9C120D20MP12	CM61DE4A1	1.00	0.98	1.06
TPLC100C20MP12	CM61CE4A1	1.00	0.97	1.04
TPLC120C20MP12	CM61CE4A1	1.00	0.97	1.04
YP9C100C20MP12	CM61CE4A1	1.00	0.98	1.07
YP9C120D20MP12	CM61DE4A1	1.00	0.98	1.06
YPLC100C20MP12	CM61CE4A1	1.00	0.97	1.04
YPLC120C20MP12	CM61CE4A1	1.00	0.97	1.04

FURNACE MULTIPLIERS - 5 TON

Furnaces	Coil	T.C.	S.C.	KW
TM8V100C20MP11	CM61CE4A1	1.00	0.97	1.04
TM8V120C20MP11	CM61CE4A1	1.00	0.97	1.04
TM9V100C20MP11	CM61CE4A1	1.00	0.98	1.07
TM9V120D20MP11	CM61DE4A1	1.00	0.98	1.06